



Project Name _____

Item No. _____

Quantity _____

Countertop Units

SPECIFICATIONS

- All range tops can be configured into countertop units by simply adding counter-height (4") legs.
- For additional detailed information please refer to each specific product page.
- Sealed Burner Range Tops
- Hot Tops
- French Tops
- Griddles
- Charbroilers
- Planchas

MODEL NUMBERS

Choose a product and one of the following counter 4" legs kits:

- 4 counter 4" legs (AV4CL)
- 6 counter 4" legs (AV6CL)
- 8 counter 4" legs (AV8CL)

STANDARD FEATURES

- 1¼" front gas manifold
- 1" rear gas supply connection
- Stainless steel front, sides, and bottom
- Welded steel frame
- Welded body construction
- Stainless steel front plate shelf 3½"
- 9" low back flue riser



V36B6
shown with optional 4" legs (AV4CL)

OPTIONS

- Stainless steel back
- Common multi-unit plate shelf up to 108"
- Extended plate shelf 6"
- Extended plate shelf 8"
- Belly bar with 1" space
- Belly bar with space for 1/9 condiment pans
- Cap and cover manifold ends
- 1" island trim
- 1" pressure regulator (shipped separately)



Project Name _____

Item No. _____

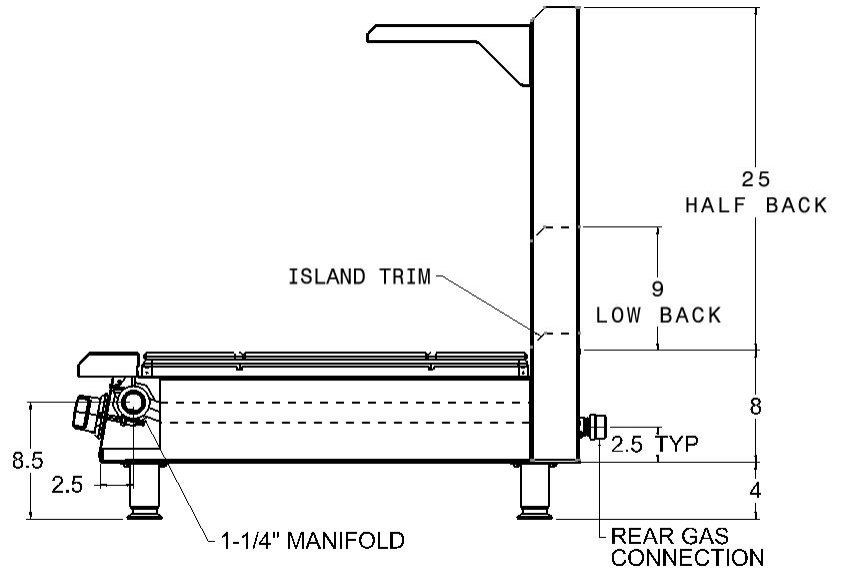
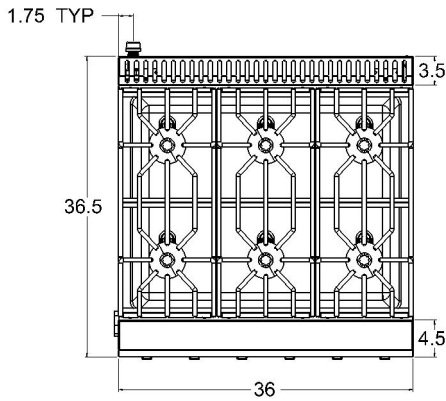

UTILITY INFORMATION

| Model | Description | Gas [BTU/Hr] | Approx SHP WT | <p>GAS: Each unit to have a 1 1/4" front manifold that couples to adjacent equipment or is capped. A 1" male NPT rear gas connection may be used for a gas supply or capped if supply is from adjacent unit(s). Minimum gas supply is 6" W.C. for natural gas and 11" W.C. for propane. Operating Pressure is 5" W.C. for natural gas and 10" for propane at the manifold. All units require a regulated gas supply (pressure regulator must be ordered as an option).</p> <p>EXHAUST: Installation under an exhaust hood is required.</p> <p>Specify type of gas when ordering. Specify altitude when above 2000 ft.</p>  |
|--|-------------|--------------|---------------|---|
| <p>(PLEASE REFER TO SPECIFIC PRODUCT PAGE)</p> | | | | |

Note: When used as counter units, the Tall Back risers/shelves are not available. Tall backs are for units with oven, cabinet base or refrigerated base only. Viking Commercial products are not approved or recommended for residential use.

Note: In line with company policies, Viking Range Corporation reserves the right to change material and specifications without notice.