



Project Name _____

Item No. _____

Quantity _____

French Top Modular Range Top

[with 18" Top Plate]

SPECIFICATION

- Heavy Duty modular front-fired French Top rangetop. 18" wide French Tops consist of polished cast iron plate with bottom studs for additional heat conduction efficiency. Two-ring insert is removable to allow use as open burner. Each 18" top has one 30,000 Btu burner that is controlled by a manual infinite valve.
- Unit to have stainless steel front, sides and bottom, welded angle frame and 1 1/4" front manifold with 1" rear gas connection.
- Available in 18" and 36" combinations.
- Models: V18F and V36F2 or in combination with other tops.
- This unit is modular and mounts on a standard oven, convection oven, cabinet base, refrigerated base or 4" legs for counter models. One of these must be ordered to complete this unit. See separate spec sheets for bases.

STANDARD FEATURES

- Burner 30,000 Btu, one per 18" section
- Standing Pilots, one per burner
- 1 1/4" Front Gas Manifold
- 1" Rear gas supply connection
- Zamak Die Cast Knobs with set screws
- Stainless Steel front, sides and bottom
- Welded Steel frame
- Welded Body construction
- Stainless Steel Front Plate shelf 3 5/8"
- 9" Low Back Flue Riser



V36F2

OPTIONS

- Stainless Steel Back
- Common Multi-unit Plate Shelf up to 108"
- Extended Plate Shelf 6"
- Extended Plate Shelf 8"
- Belly Bar with 1" space
- Belly Bar with space for 1/9 condiment pans
- Cap and Cover manifold ends
- Flue Risers: 1" Island Trim, 25" high Half Back or 39" high Tall Back
- Shelving: single, 25" or 39" high and double 39" high with either solid shelf, tubular or a combination
- Legs 4" high for counter models
- 1" Pressure regulator (shipped separately)

Note: All Viking units are modular. Rangetops are separate units and have separate model numbers from bases. To complete a range there must be a base item added, such as oven, cabinet base, refrigerated base or legs.

Example: A 6 burner range with oven would be a V36B6 plus a V36SO



Project Name _____

Item No. _____

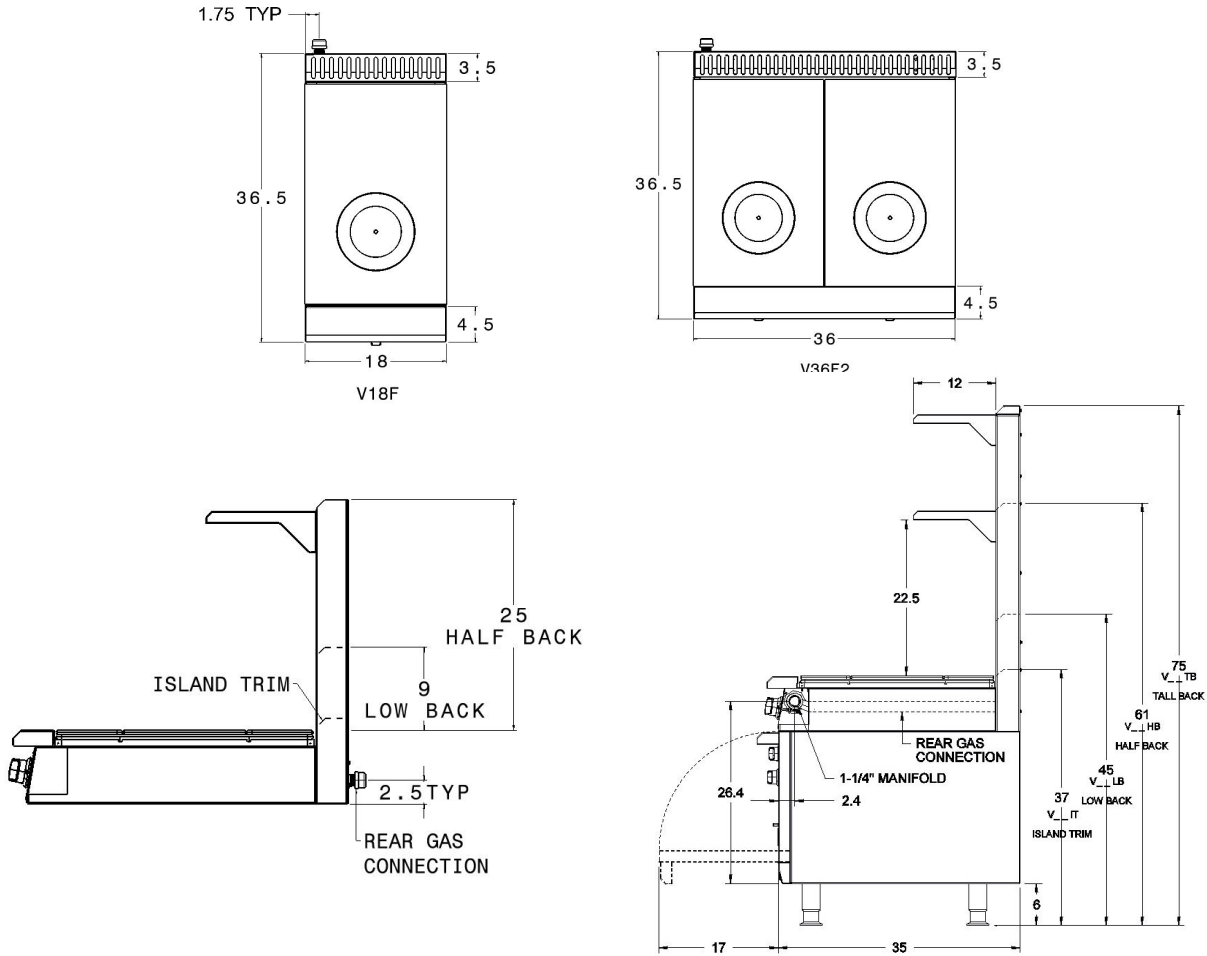

UTILITY INFORMATION

Model	Description	Gas [Btu/HR]	Approx SHP WT
V18F	1-18" French top	30,000	250 lb
V36F2	2-18" French tops	60,000	400 lb

Specify type of gas when ordering.
Specify altitude when above 2000 ft.



GAS: Each unit to have a 1 1/4" front manifold that couples to adjacent equipment or is capped. A 1" male NPT rear gas connection may be used for a gas supply or capped if supply is from adjacent unit(s). Minimum gas supply is 6" W.C. for natural gas and 11" W.C. for propane. Operating Pressure is 5" W.C. for natural gas and 10" for propane at the manifold. All units require a regulated gas supply (pressure regulator must be ordered as an option).

ELECTRICAL: No electrical requirements for top modules. Only convection oven base or refrigerated base requires electricity.

EXHAUST: Installation under an exhaust hood is required.

Note: When used as counter units, the Tall Back risers/shelves are not available. Tall backs are for units with oven, cabinet base or refrigerated base only. Viking Commercial products are not approved or recommended for residential use.

Note: In line with company policies, Viking Range Corporation reserves the right to change material and specifications without notice.