



Project Name _____

Item No. _____

Quantity _____

Refrigerated Bases

SPECIFICATION

- Heavy-duty refrigerated bases with a modular design for maximum configuration and design flexibility. Unit is to have stainless steel front, sides, and welded steel frame.
- Cooktops bolt directly to base without legs.
- All drawers accommodate 6" deep 12"x20" hotel pans. Ultra high-quality drawer slides that can withstand 275 lbs.
- Compressor compartment panel is front accessible and removable. Self-contained compressor compartment is 11.5" wide – smallest in the industry – enables greater pan capacity.
- Available in sizes of 36", 48", 60", 72", 84", 96", and 108" widths for both remote and self-contained models.

STANDARD FEATURES

- Front accessible compressor with removable compartment panel
- Full-width heavy-duty beveled drawer handle
- High-quality drawer slides – can withstand 275 lbs. capacity
- Drawer track removable for replacement or cleaning
- Drawers to accommodate 12"x20"x6" deep pans
- Snap-in magnetic gasket
- Welded Steel frame
- 2.5" thick top insulation for maximum heat protection
- Self-contained compressor – 1/5hp, R134A, 120 volts and 20 amps
- 11.5" wide compressor compartment for self-contained models
- Adjustable legs 6" high with plate mounting



V72RBS

OPTIONS

- Remote (R) or Self-contained (S)
- 6" High swivel casters, 2 with brakes
- 6" High adjustable casters, 2 with brakes

Note: All Viking units are modular. Rangetops are separate units and have separate model numbers from bases. To complete a range there must be a base item added, such as oven, cabinet base, refrigerated base or legs.

Example: A 6 burner range with oven would be a V36B6 plus a V36SO



Project Name _____

Item No. _____

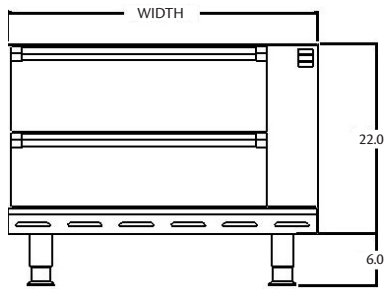

REMOTE

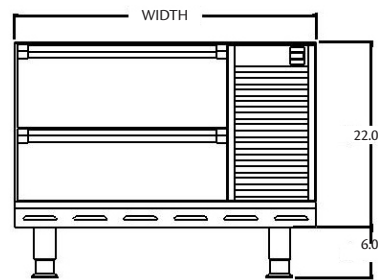

SELF-CONTAINED

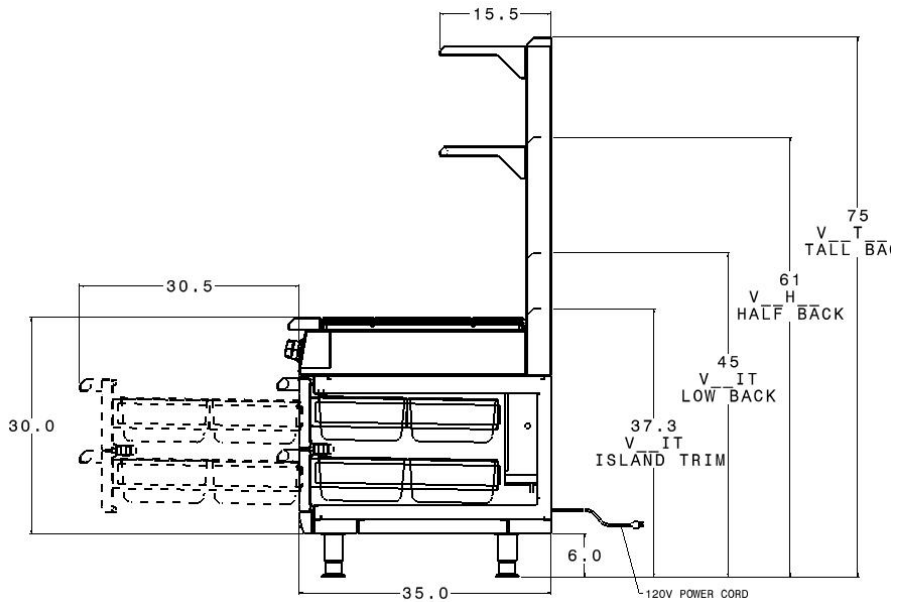

UTILITY INFORMATION

Model	Description	BTU's		# of Pans/Drawers		Approx. Shipping Wt.	
		R	S	R	S	R	S
V36RB_	36" Refrigerated Base	1,000	700	4/2	4/2	350 lbs	440 lbs
V48RB_	48" Refrigerated Base	1,300	800	6/4	4/2	450 lbs	540 lbs
V60RB_	60" Refrigerated Base	1,700	1,300	8/4	6/4	550 lbs	640 lbs
V72RB_	72" Refrigerated Base	2,100	1,800	10/4	8/4	650 lbs	740 lbs
V84RB_	84" Refrigerated Base	2,400	2,100	10/6	10/4	750 lbs	840 lbs
V96RB_	96" Refrigerated Base	2,800	2,300	12/6	10/6	850 lbs	940 lbs
V108RB_	108" Refrigerated Base	3,200	2,700	14/8	12/6	950 lbs	1040 lbs

* Suffix: R = Remote S = Self-Contained

Note: Please contact factory for actual drawer sizes and dimensions.

ELECTRICAL: 1/5 hp, 120 Volts, 20 amps for self-contained models.

EXHAUST: No exhaust requirements for refrigerated bases.

GAS: No gas requirements for refrigerated bases.

Specify type of gas when ordering. Specify altitude when above 2000 ft.



Note: When used as counter units, the Tall Back risers/shelves are not available. Tall backs are for units with oven, cabinet base or refrigerated base only. Viking commercial products are not approved or recommended for residential use.

Note: In line with company policies, Viking Range Corporation reserves the right to change material and specifications without notice.