



Project Name _____

Item No. _____

Quantity _____

Salamander

SPECIFICATION

- Heavy-duty gas infrared salamander broiler with a unique open C-shaped design.
- Powerful ceramic infrared burner with tilted design for heat deflection from user and controls. Burner has protective screen to prevent inadvertent damage.
- Counterweighted rack mechanism for smooth vertical and horizontal movement and control.
- Unique feature allows carriage to float vertically when desired. Lock and release knob for rack position and heat control. Large heavy duty chrome plated broiling rack.
- Unit is to have stainless steel front, sides, bottom and interior.
- Available in sizes of 36" and 48" wide

STANDARD FEATURES

- Ceramic infrared burner @ 30,000 Btu/hr for a 36" unit and 40,000 Btu/hr for 48" unit with protective screen
- Front accessible ON/OFF gas valve
- Zamak die cast knob with set screw
- Stainless steel front, sides, bottom and interior
- Welded body construction
- Removable drip tray
- Standing pilot ignition
- Chrome plated end caps with beveled rack handle
- Front accessible rack handle for easier vertical and horizontal movement control



V36SMW

OPTIONS

- Range mount(R), Wall mount(W), or Counter(C) models
- Example: A 36" range mount salamander would be V36SMR
- Counter models (C) include a bottom base with 4" legs
- Range mount (R) models include and are attached to a Tall Back
- Hanging pan rack
- 3/4" pressure regulator (shipped separately)

Note: All Viking units are modular. Rangetops are separate units and have separate model numbers from bases. To complete a range there must be a base item added, such as oven, cabinet base, refrigerated base or legs.

Example: A 6 burner range with oven would be a V36B6 plus a V36SO



Project Name _____

Item No. _____

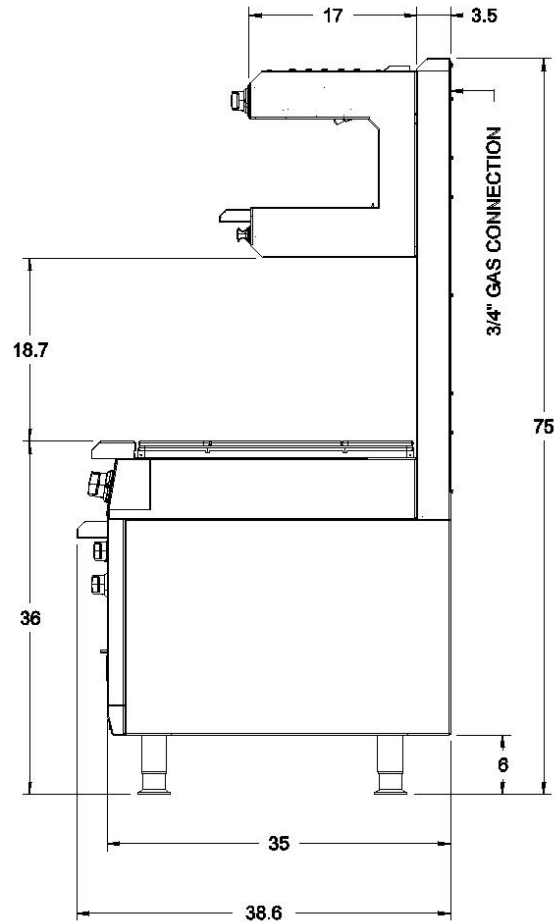
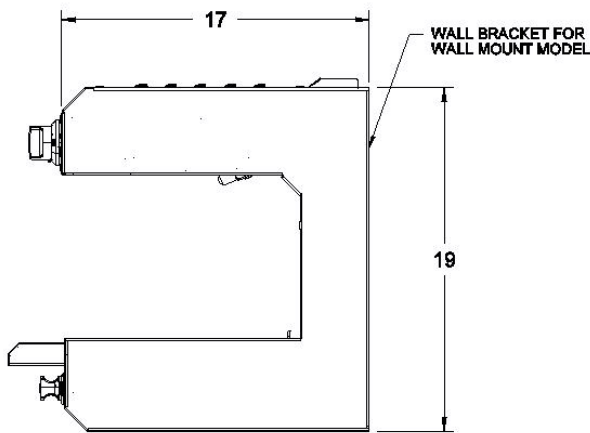
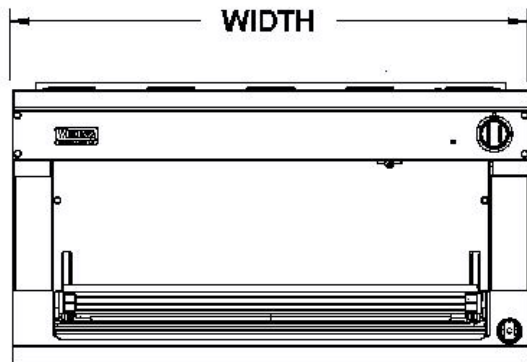

UTILITY INFORMATION

Model	Description	Gas [BTU/HR]	Approx SHP WT
V36SM__	36" wide Salamander	30,000	240 lb
V48SM__	48" wide Salamander	40,000	300 lb

GAS: Minimum gas supply is 6" W.C. for natural gas and 10" W.C. for propane. Operating Pressure is 5" W.C. for natural gas and 10" for propane at the manifold. All units require a regulated gas supply

ELECTRICAL: No electrical requirements for salamanders.

EXHAUST: Installation under an exhaust hood is required.

Specify type of gas when ordering.
Specify altitude when above 2000 ft.



Note: Range mount (R) models include a Tall Back attached. Counter models (C) include a bottom base with legs. Viking Commercial products are not approved or recommended for residential use.

Note: In line with company policies, Viking Range Corporation reserves the right to change material and specifications without notice.