



Project Name _____

Item No. _____

Quantity _____

Split Top Modular Range Top

[with 4 or 6 Burners]

SPECIFICATION

- Heavy Duty modular range top with 2-piece removable sealed burners, 30,000 Btu each. Burners mount on #304 Stainless Steel bowl for ease of cleaning. Each burner to have a standing pilot. Burner grates are ½" diameter welded and polished #304 Stainless Steel rod, 12" wide, and are adjustable in height for leveling. Each half Hot Top plate has one burner at 16,000 Btu 12" wide half Hot Top consists of highly polished cast iron plate with bottom studs for additional heat efficiency.
- Unit to have stainless steel front, sides, and bottom, welded steel frame and 1½" front manifold with 1" rear gas connection.
- Models: V24S4, V36S6, or in combination with other available tops.
- This unit is modular and mounts on a standard oven, convection oven, cabinet base, refrigerated base, or 4" legs for counter models. One of these bases must be ordered to complete the unit. See separate spec sheets for bases.

STANDARD FEATURES

- Sealed burners 30,000 Btu each, two-piece lift-off
- Hot Top burners 16,000 Btu each, one per half Hot Top
- #304 Stainless Steel bowl for easy cleaning
- #304 Stainless Steel ½" rod half grates, adjustable height for leveling
- Standing Pilots, one per burner
- 1 ¼" Front Gas Manifold
- 1" Rear gas supply connection
- Zamak Die Cast Knobs with set screws
- Stainless Steel front, sides, and bottom
- Welded steel frame
- Welded body construction
- Stainless Steel Front Plate shelf 3⅝"
- 9" Low Back Flue Riser

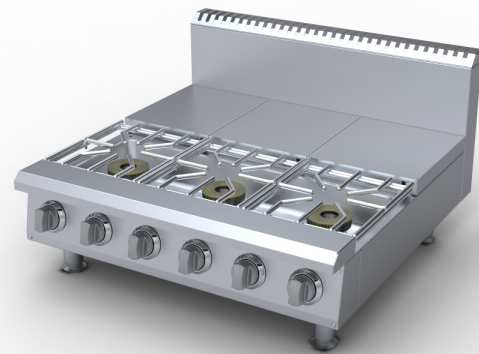

V36S6

OPTIONS

- Stainless Steel Back
- Common Multi-unit Plate Shelf up to 108"
- Extended Plate Shelf 6"
- Extended Plate Shelf 8"
- Belly Bar with 1" space
- Belly Bar with space for 1/9 condiment pans
- Cap and Cover manifold ends
- Flue Risers: 1" Island Trim, 25" high Half Back or 39" high Tall Back
- Shelving: single, 25" or 39" high and double 39" high with either solid shelf, tubular, or a combination
- Legs 4" high for counter models
- 1" Pressure regulator (shipped separately)

Note: All Viking units are modular. Rangetops are separate units and have separate model numbers from bases. To complete a range there must be a base item added, such as oven, cabinet base, refrigerated base or legs.

Example: A 6 burner range with oven would be a V36B6 plus a V36SO



Project Name _____

Item No. _____

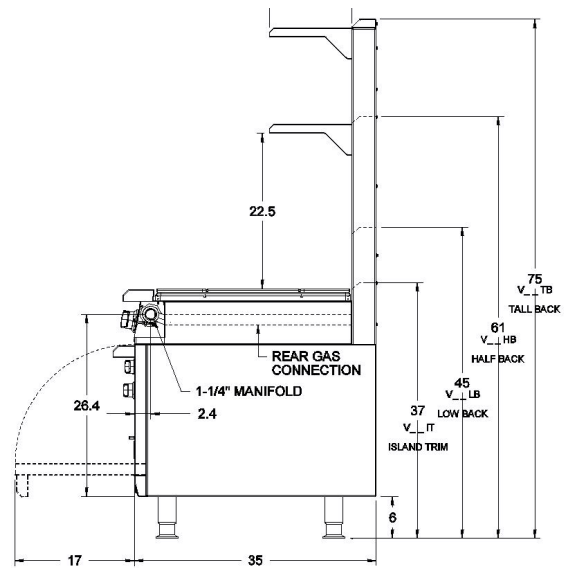
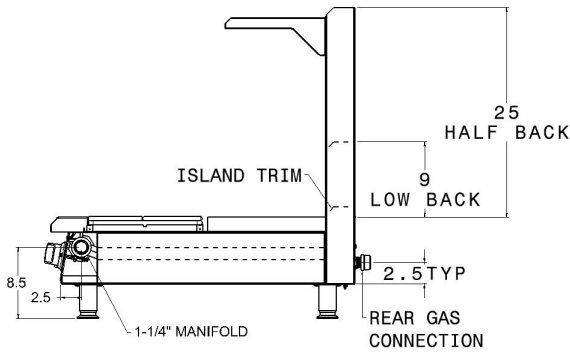
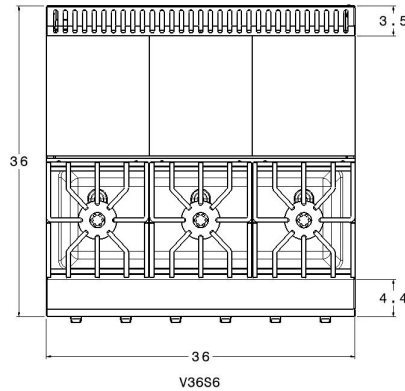
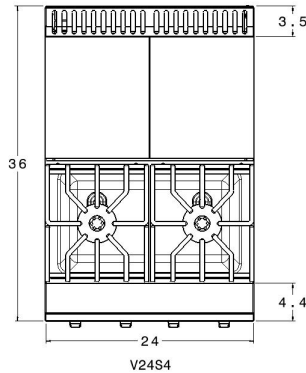

UTILITY INFORMATION

Model	Description	Gas [Btu/HR]	Approx SHP WT
V24S4	Two 12" 2 Split Top	92,000	250 lb
V36S6	Three 12" 2 Split Top	138,000	400 lb

Specify type of gas when ordering.
Specify altitude when above 2000 ft.



GAS: Each unit to have a 1 1/4" front manifold that couples to adjacent equipment or is capped. A 1" male NPT rear gas connection may be used for a gas supply or capped if supply is from adjacent unit(s). Minimum gas supply is 6" W.C. for natural gas and 11" W.C. for propane. Operating Pressure is 5" W.C. for natural gas and 10" for propane at the manifold. All units require a regulated gas supply (pressure regulator must be ordered as an option).

ELECTRICAL: No electrical requirements for top modules. Only convection oven base or refrigerated base requires electricity.

EXHAUST: Installation under an exhaust hood is required.

Note: When used as counter units, the Tall Back risers/shelves are not available. Tall backs are for units with oven, cabinet base, or refrigerated base only. Viking Commercial products are not approved or recommended for residential use.

Note: In line with company policies, Viking Range Corporation reserves the right to change material and specifications without notice.