



Project Name _____

Item No. _____

Quantity _____

Step Up Modular Range Top

[with 4 or 6 Burners]

SPECIFICATION

- Heavy Duty modular range top with 2-piece removable sealed burners, 30,000 Btu each. Burners mount on #304 Stainless Steel bowl for ease of cleaning. Each burner to have a standing pilot. Burner grates are ½" diameter welded and polished #304 Stainless Steel rod, 12" wide, and are adjustable in height for leveling.
- Unit to have stainless steel front, sides, and bottom, welded steel frame and 1¼" front manifold with 1" rear gas connection.
- Models: V24E4, V36E6, or in combination with other available tops.
- This unit is modular and mounts on a standard oven, convection oven, cabinet base, refrigerated base, or 4" legs for counter models. One of these bases must be ordered to complete the unit. See separate spec sheets for bases.

STANDARD FEATURES

- Sealed burners 30,000 Btu each, two-piece lift-off
- #304 Stainless Steel bowl for easy cleaning
- Rear burners are elevated by 4"
- #304 Stainless Steel ½" rod half grates, adjustable height for leveling
- Standing Pilots, one per burner
- 1 ¼" Front Gas Manifold
- 1" Rear gas supply connection
- Zamak Die Cast Knobs with set screws
- Stainless Steel front, sides, and bottom
- Welded steel frame
- Welded body construction
- Stainless Steel Front Plate shelf 3⅝"
- 9" Low Back Flue Riser



V36E6

OPTIONS

- Stainless Steel Back
- Common Multi-unit Plate Shelf up to 108"
- Extended Plate Shelf 6"
- Extended Plate Shelf 8"
- Belly Bar with 1" space
- Belly Bar with space for 1/9 condiment pans
- Cap and Cover manifold ends
- Flue Risers: 25" high Half Back or 39" high Tall Back
- Shelving: single, 25" or 39" high and double 39" high with either solid shelf, tubular, or a combination
- Drop-in catch pans, dishmachine washable #304 Stainless Steel
- Legs 4" high for counter models
- 1" Pressure regulator (shipped separately)

Note: All Viking units are modular. Rangetops are separate units and have separate model numbers from bases. To complete a range there must be a base item added, such as oven, cabinet base, refrigerated base or legs.

Example: A 6 burner range with oven would be a V36B6 plus a V36SO



Project Name _____

Item No. _____

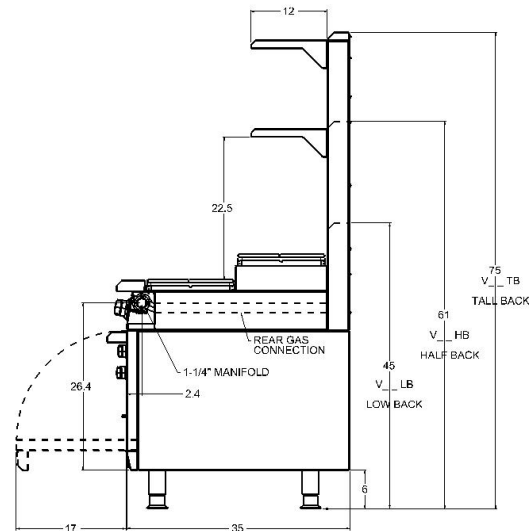
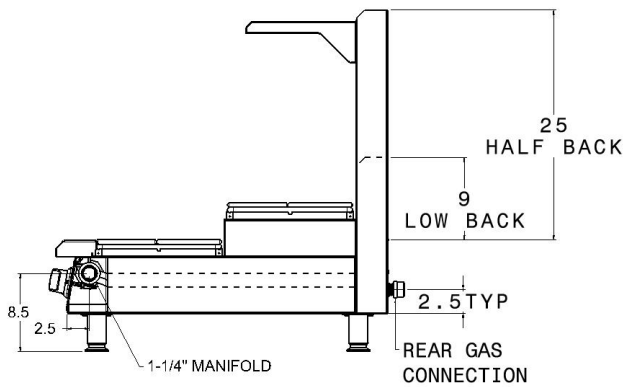
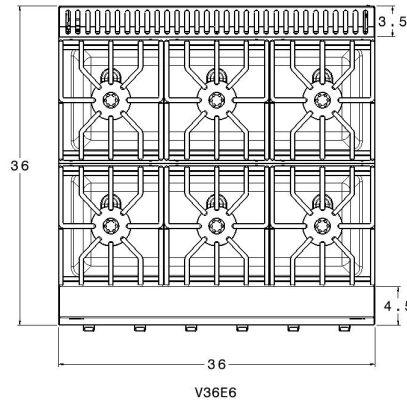
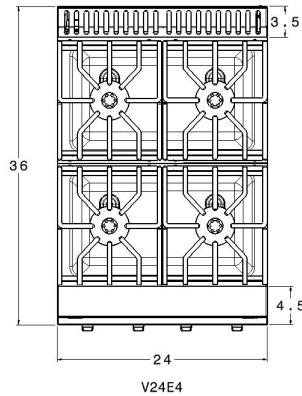

UTILITY INFORMATION

Model	Description	Gas [Btu/HR]	Approx SHP WT
V24E4	Two 12" 2 Elevated Burner Top	120,000	160 lb
V36E6	Three 12" 2 Elevated Burner Top	180,000	240 lb

GAS: Each unit to have a 1 1/4" front manifold that couples to adjacent equipment or is capped. A 1" male NPT rear gas connection may be used for a gas supply or capped if supply is from adjacent unit(s). Minimum gas supply is 6" W.C. for natural gas and 11" W.C. for propane. Operating Pressure is 5" W.C. for natural gas and 10" for propane at the manifold. All units require a regulated gas supply (pressure regulator must be ordered as an option).

ELECTRICAL: No electrical requirements for top modules. Only convection oven base or refrigerated base requires electricity.

EXHAUST: Installation under an exhaust hood is required.



Specify type of gas when ordering.
Specify altitude when above 2000 ft.

Note: When used as counter units, the Tall Back risers/shelves are not available. Tall backs are for units with oven, cabinet base, or refrigerated base only. Viking Commercial products are not approved or recommended for residential use.

Note: In line with company policies, Viking Range Corporation reserves the right to change material and specifications without notice.